



60,000-175,000 BTU/HR Heaters For:

- *Manufacturing Plants*
- *Truck Terminals*
- *Repair Shops & Garages*
- *Warehouses*
- *Aircraft Hangers*
- *Fire Stations*
- *Green Houses*
- *Automobile Dealerships & Body Shops*
- *Loading Docks*
- *Farm Buildings*
- *Indoor Sporting Arenas*
- *Stables*
- *Custom Applications*

America's Most Complete Line Of Infrared Heaters!

HIGHLY EFFICIENT AND COST EFFECTIVE RADIANT TUBE HEAT.

- Full 10-Year Limited Warranty
- 16-Gauge Aluminized Tubing
- Outside Or Inside Air For Combustion
- Sealed Burner Control Box
- Full Cover Polished Aluminum Reflector
- Installs Easily As "Straight" Or "U-Tube" Configurations

Features

- Available In 20 To 60 Foot System Lengths
- Horizontal Or 45 Degree Angle Of Reflectors
- Stainless Steel Couplers
- Chrome Plated Hanging Brackets
- Burner Sight Glass
- All Components Are Name-Brand Non-Proprietary
- 24 Volt Or Line Voltage Thermostat Installation Option

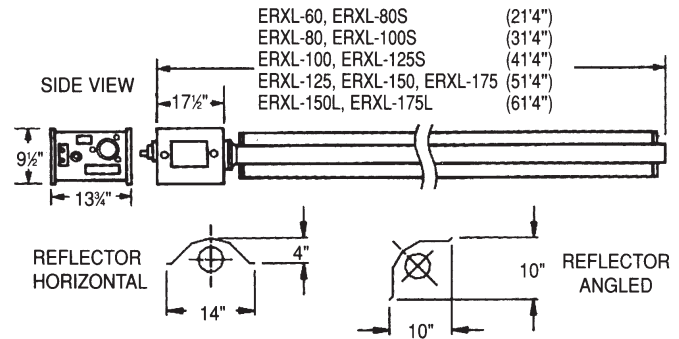

DIMENSIONS

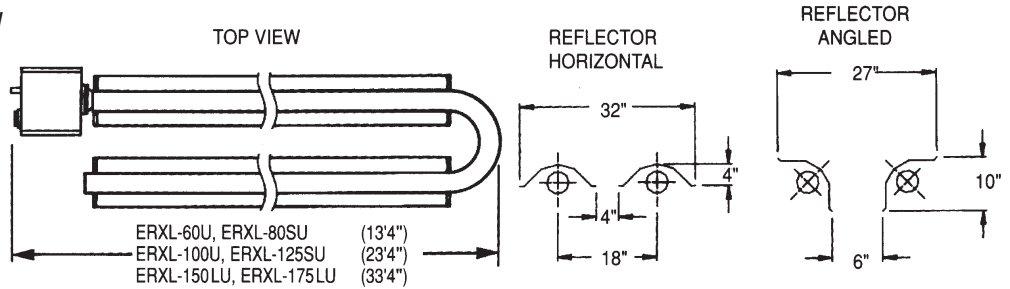

CSA Certified

SPECIFICATIONS & TECHNICAL DATA

MODEL NUMBER BTU x 1000	LENGTH	MOUNTING CLEARANCE TO COMBUSTIBLES				TYPICAL MOUNTING HEIGHT	SHIPPING WEIGHT (LBS)	ELECTRICAL 120 volt-60 Hz Starting Current 5.0 amps Running Current 1.0 amps BURNER Heaters are equipped with a silicon carbide hot surface ignition and electronic safety circuitry COMBUSTION CHAMBER / HEAT EXCHANGER 4" Aluminized steel tubing - 16 gauge GAS SUPPLY Natural Gas Min 4.6" w.c. - Max 14.0" w.c. LP Gas Min 11.0" w.c. - Max 14.0 w.c. FLUE CONNECTION GAS CONNECTION 4" (O.D.) 1/2" NPT WARRANTY 10-year limited warranty on all electrical components, burner and tubes
		FROM TOP - HORIZONTAL	FROM TOP - AT 45° ANGLE	STRAIGHT BELOW	SIDE			
ERXL 60 N/LP*	20'	6"	12"	55"	36"	10'-14'	110	
ERXL 80S N/LP	20'	6"	18"	55"	36"	12'-15'	110	
ERXL 80 N/LP	30'	6"	18"	55"	36"	12'-15'	110	
ERXL 100S N/LP	30'	6"	18"	74"	36"	12'-15'	130	
ERXL 100 N/LP	40'	6"	18"	74"	36"	12'-15'	150	
ERXL 125S N/LP	40'	6"	18"	87"	36"	14'-19'	150	
ERXL 125 N/LP	50'	6"	18"	87"	36"	14'-19'	170	
ERXL 150 N/LP	50'	6"	18"	87"	36"	15'-25'	170	
ERXL 150L N/LP	60'	6"	18"	87"	36"	15'-25'	190	
ERXL 175 N/LP	50'	6"	18"	87"	36"	15'-25'	170	
ERXL 175L N/LP	60'	6"	18"	87"	36"	15'-25'	190	

* N = Natural Gas LP = Propane